

The World Leader in High Performance Signal Processing Solutions



## uClinux for Blackfin ADEOS

*JUNE 2006*



# LCD





# ADEOS Hard Real Time



# Real Time Scheduling in Linux - ADEOS

## ◆ ADEOS is an open source project:

- <http://home.gna.org/adeos/>
- Runs a kernel module in a higher priority interrupt task than the kernel.
- Is able to “hold” off kernel interrupts so the hard real time task can be completed
- We have an ADEOS patch for our kernel, and are looking at performance measurements now.
- Also looking for customers who have this requirement (Hard Real Time application under uClinux) so we can develop examples



# Real Time Layer

**Hypothesis: Embedded Processing users expect to have a host applications Processor and a real time processor in their system (ARM + DSP).**

## ADEOS FEATURES

- Flexible environment for sharing hardware resources among multiple operating systems,
- Allows multiple instances of a single OS for SMP

## BENEFIT

- Enables deterministic event processing
- Virtual partitioning of RT and Application processes
- Customer acceptance of partition

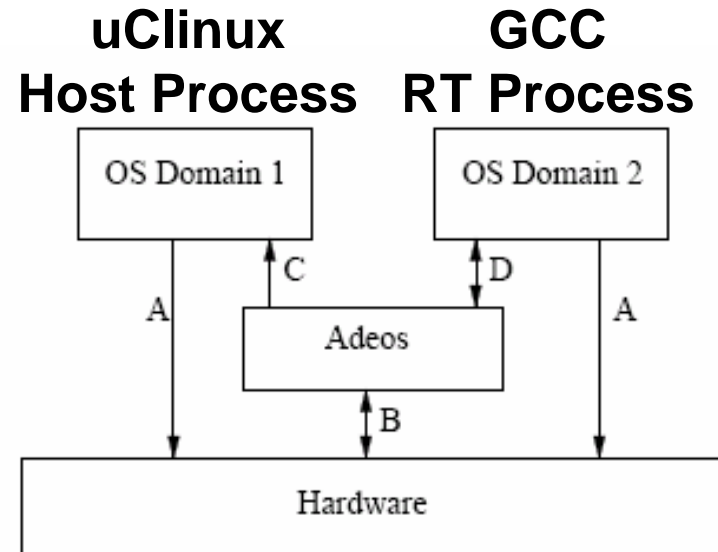
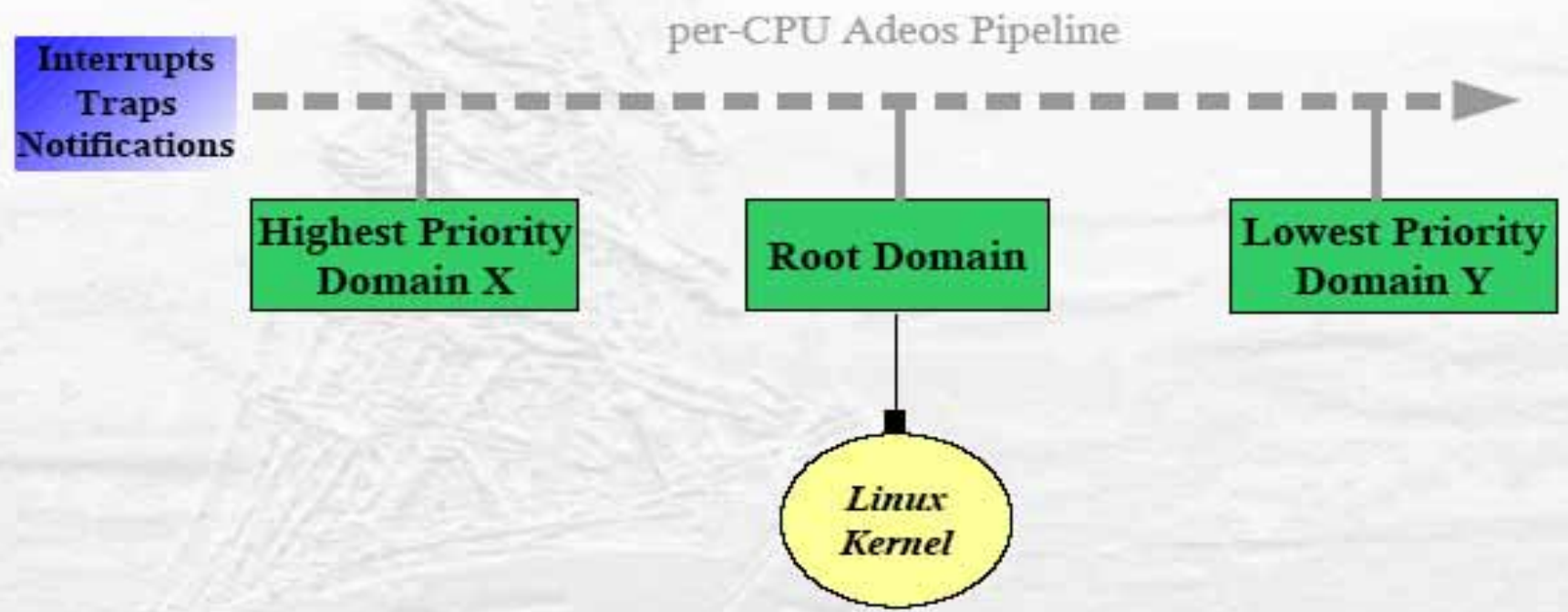

Figure 1: Adeos architecture.



# ADEOS nanokernel scheme



# ADEOS Internals

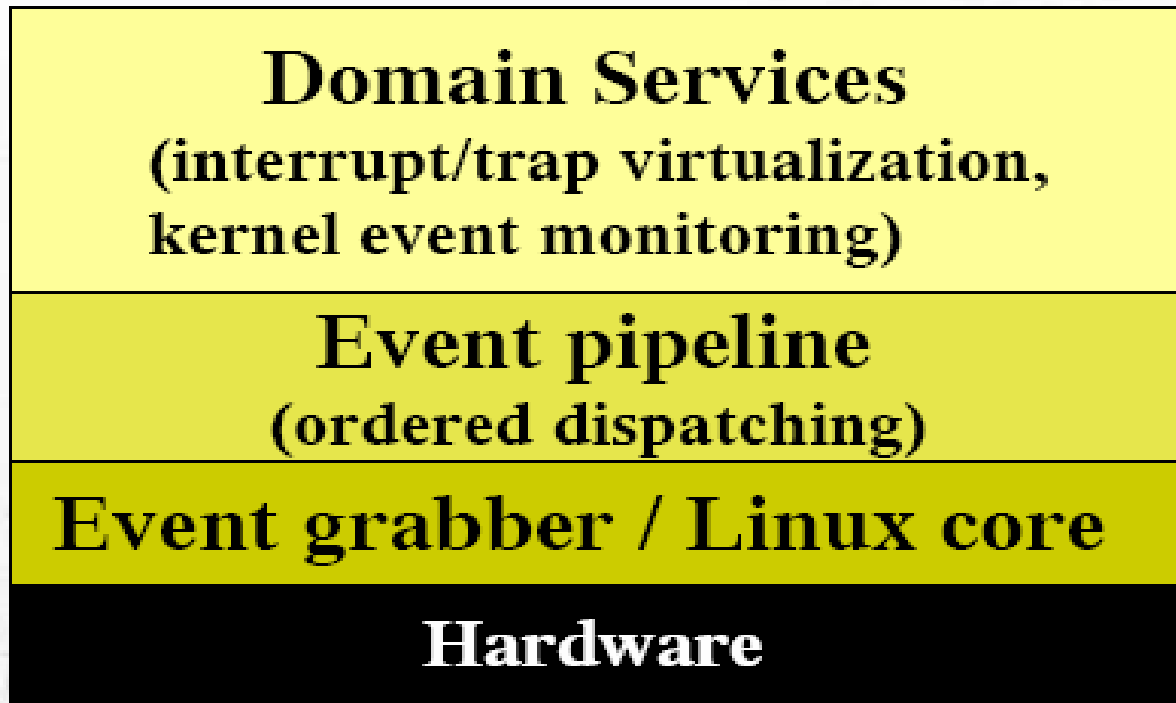

- ▶ Domain programming API
- ▶ Event ordering and dispatching
- ▶ Low-level interposition



# ADEOS Services

- ◆ **Per-domain event virtualization**
  - Hardware interrupts
  - Processor traps
  - Linux kernel notifications
  
- ◆ **Pipeline control**
  - Domain registration
  - Event propagation (accept, pass, terminate, discard)
  - Stage stalling / unstalling (Stodolsky-based)
  
- ◆ **Inter-domain mutexes (w/priority inheritance)**





# Xenomai – A framework for running real time application on Linux

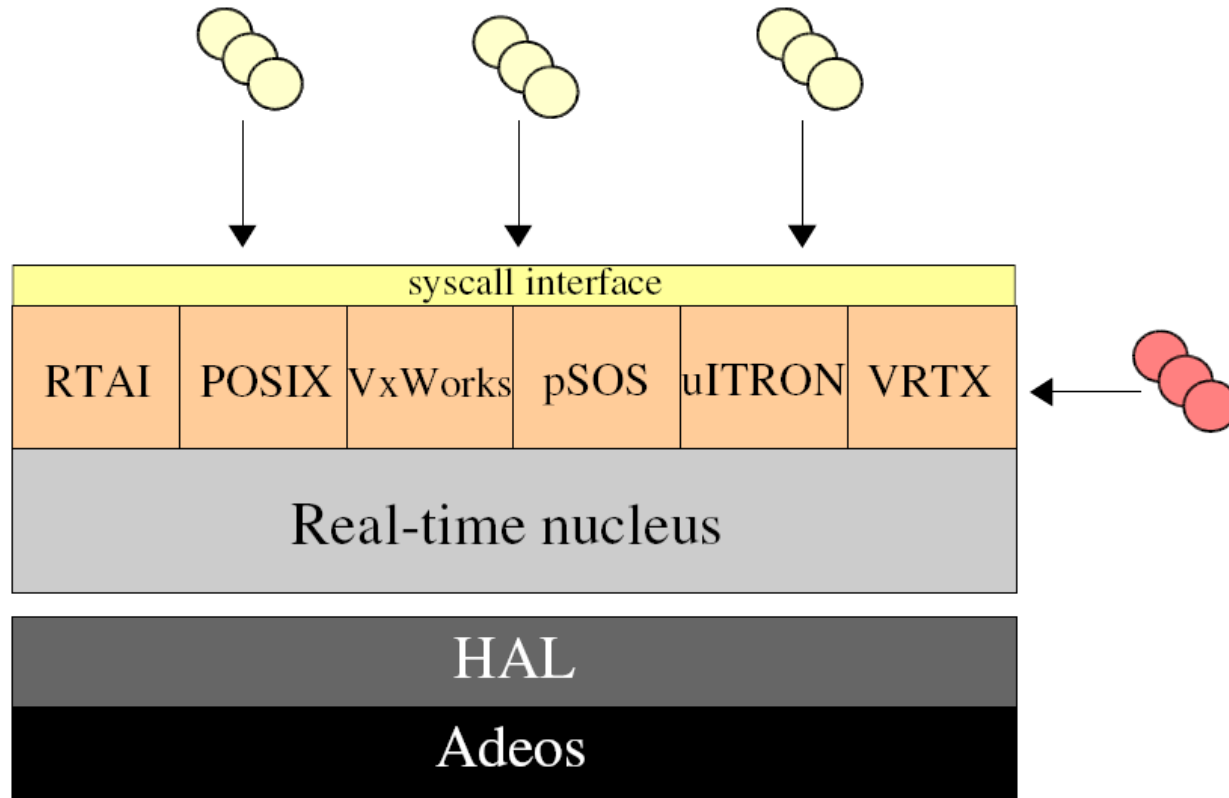

User-space applications

Kernel-based applications



# Xenomai - Using ADEOS services

Regular Linux service

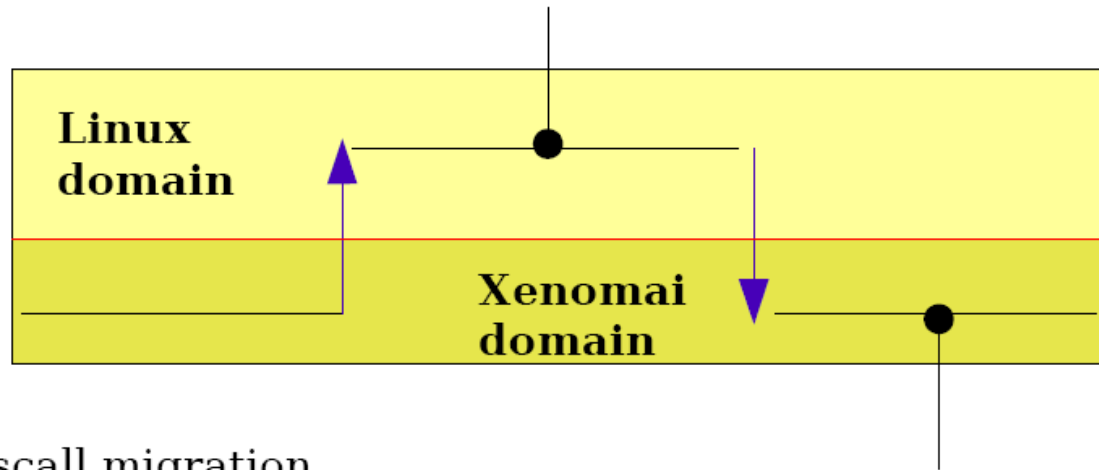

- ▶ Syscall migration
- Xenomai Task execution
- Native API call
- Interrupt shield

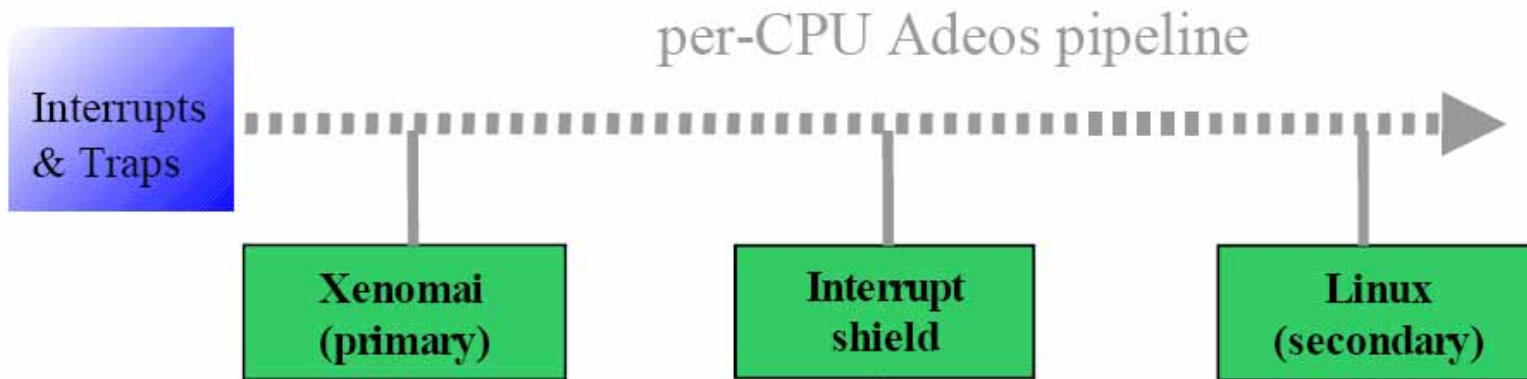



# Xenomai features:

- ◆ **Emulators make it easy to port existing RT applications to Linux**
- ◆ **Real time threads running in user space or kernel space – Deterministic scheduling latencies whatever activity Linux is undergoing.**
- ◆ **Xenomai provides a set of new APIs for real time application:**
  - **Task management**
  - **Timing**
  - **Synchronization – Semaphores, Mutex, Event flags, Condition variables**
  - **Messaging and communication**
  - **Independent of context – kernel or user space**
- ◆ **Xenomai and ADEOS is ported to Blackfin uClinux 2005R4 Release**

